

# GUILLOTINE SHEARS



Think Big, We Do.

O.S.B. Lacivert Cd. 2.Sk. No.1/A 16140 Nilüfer BURSA/TURKEY  
T : +90 224 294 77 00 F : +90 224 243 12 86  
E-mail : baykal@baykal.com.tr

   / BaykalMachinery

05 / 2023 - REV / 01

**Baykal**



**“ THINK BIG, WE DO. ”**

**READY 4.0  
CHANGE**





## From Past to *Future*

With a foundation history going back to the early 1950s, Baykal today is placed as a leading manufacturer and global supplier of sheet metal working machinery specializing in the production of press brakes, shears, notchers, punching machines, laser cutting systems, plasma cutting machines, and Vertical Machining Centers.

For its manufacturing operations, Baykal utilizes three factories which together combine a production area of 70,000 square meters, making it one of Europe's largest facilities for sheet metalworking and fabricating machinery. The total workforce at Baykal is currently numbered at 650 employees and is composed of highly trained and qualified machine operators and assembly technicians supported by a staff of 80 engineers. All the machines offered by Baykal are designed, manufactured, assembled, and finished wholly at Baykal's purpose-built plants in a CAD environment with extensive use of CNC machining and modern workshop equipment.

Baykal company is accredited for the ISO 9001 Certification issued by the German TÜV NORD institution. Also, since 1995, Baykal has been building machines in conformity with the European CE regulations for safety, being the first Turkish machine-tool manufacturer certified eligible to bear the CE Mark on its products. In addition, all Baykal products are manufactured with the TSE and TSEK quality certificates issued by the Turkish Standards Institution.

Since the last 50 years, Baykal has progressed to become a major exporter of sheet metal working machines to the world markets with customers located in all the machine-tool consuming countries of the global geography from the Americas to Australasia. Baykal is currently represented in over 100 countries worldwide through appointed dealers. In the base market of Turkey, Baykal sheet metal working machines have traditionally commanded a leading market share thanks to the company's pioneering role in the development of Turkey's machine industry and its never-lessening emphasis on quality and service. Here, with a long engineering experience behind it, Baykal wishes to present itself as a quality-conscious, professional machine-building company serving the industry.

# HNC · HYDRAULIC VARIABLE-RAKE GUILLOTINES

Outstanding cutting quality and accuracy. Design with “variable-rake” concept.

01

## Maximum Capacity

It is possible to make superior and unique processes with its maximum cutting capacity.

02

## Flexibility

HNC gives flexibility to its user with thin and thick sheet metal material cutting choices





03

### **Reliable**

Work easily – Reliable Processes,  
high quality

04

### **Productivity**

High productivity, high sensitivity  
and affective production cost to  
your production



**Variable-Rake**



**1000mm  
Back Gauge**



**Up to  
10100mm**



**Up to 60 mm  
(MS)**



**Special Sizes  
Available**





# HNC • HYDRAULIC VARIABLE-RAKE GUILLOTINES

## DESIGN AND OPERATING FEATURES

- Rigidly welded all-steel frame construction.
- Design with “variable-rake” concept.
- Adjustment of machine functions with easy-to-use digital control units.
- Extra deep (350 mm) side frame throat gaps allowing continuous strip slitting.
- Swing-up backgauge system for shearing longer pieces than backgauge range.
- Backgauge system with ballscrews.
- Backgauge retract function.
- Adjustable stroke length to increase number of strokes on shorter cuts.
- Compact, low-maintenance European hydraulics.
- Hydraulic holddown system.
- Hydraulic overload protection.
- Centralised manual lubrication system.

## STANDART EQUIPMENT

- Shear blades from tough and wear-resistant alloyed material:
  - Top blade: Two cutting edges.
  - Bottom blade: Four cutting edges.
- Digital control unit for backgauge positioning, rake adjustment, and blade gap setting.
- Foot pedal control for single and repetitive cutting cycles.
- 1000 mm power backgauge with ballscrew spindles to 0.1 mm precision.
- 1000 mm squaring arm with scale, T-slot and flip-stop.
- Front support arms in 1000 mm length with scale, T-slot and flip-stop.
- Digital stroke counter.
- Pendant arm.
- Work table with filler plates, ball transfers and hand slots.
- Emergency stop buttons on the pendant and on the mainframe.
- Shadow line facility with fluorescent lighting.
- See through finger guard and side throat guards.

# MGH · HYDRAULIC SWING-BEAM SHEARS

Maximum robustness. Rapid blade gap adjustment mechanism.

01

## Robust

Thanks to its long-life structure, it provides dynamic and extremely sensitive productivity

02

## Flexibility

MGH gives flexibility to its user with thin and thick sheet metal material cutting choices





03

### **Easy to Operate**

MGH is designed to provide operating possibility even in the most difficult conditions

04

### **Productivity**

MGH gives high productivity, high sensitivity and affective production cost to your production



**Swing Beam**



**1000mm  
Back Gauge**



**Up to  
4100mm**



**Up to 20 mm  
(MS)**





# **MGH** · HYDRAULIC SWING-BEAM SHEARS

## **DESIGN AND OPERATING FEATURES**

- Welded all-steel frame providing maximum rigidity and cutting accuracy.
- Swinging top beam working on high precision and self-aligning roller bearings.
- Rapid blade gap adjustment mechanism.
- Swing-up backgauge system for shearing longer pieces than maximum backgauge range.
- Backgauge retract function.
- Compact, low-maintenance hydraulic unit located above oil tank.
- Easily servicable hydraulic cylinders in series connection.
- Hydraulic holddown system.
- Hydraulic overload protection.
- Fine adjustment of blades from lower beam.
- Adjustable stroke length to increase number of strokes on shorter cuts.
- Extra deep (250 mm) side frame throat gaps allowing continuous strip slitting.

## **STANDART EQUIPMENT**

- Shear blades made from tough and wear-resistant alloyed material
  - Top blade : two cutting edges
  - Bottom blade : four cutting edges.
- 1000 mm power backgauge with ballscrew spindles to 0.1 mm precision.
- Backgauge digital readout control.
- Digital stroke counter.
- Foot pedal control for single and repetitive cutting cycles.
- 1000 mm squaring arm with scale, T-slot and flip-stop.
- Front support arms in 1000 mm length.
- Work table with filler plates, ball transfers and hand slots.
- Emergency stop buttons.
- Shadow line facility with fluorescent lighting.
- See-through finger guard and side throat guards.

# HGL · HYDRAULIC SWING-BEAM SHEARS

Swinging top beam working on high precision and self-aligning roller bearings.

01

## **Economic**

HGL contributes to your budget with its low business investment

02

## **Robust**

Thanks to its ergonomic design and long-life rigid structure, it provides dynamic and extremity sensitive productivity





03

### **Productivity**

By preferring HGL shears, you will make the best choice in its class with speed, performance and cutting sensitivity

04

### **High Precision**

Swinging top beam working on high precision and self-aligning roller bearings



**Swing Beam**



**750mm  
Back Gauge**



**Up to  
4100mm**



**Up to 8 mm  
(MS)**





# **HGL** • HYDRAULIC SWING-BEAM SHEARS

## **DESIGN AND OPERATING FEATURES**

- Welded all steel frame providing maximum rigidity and cutting accuracy.
- Top beam and work table of boxtype construction.
- Rapid blade gap adjustment mechanism.
- Swing-up backgauge system for shearing longer pieces than backgauge range.
- Backgauge retract function.
- Compact, low-maintenance hydraulic unit located underneath work table.
- Hydraulic cylinders plainly designed and easily serviceable.
- Hydraulic holddown system.
- Hydraulic overload protection.
- Fine-adjustment system for blades.
- Adjustable stroke length to increase number of strokes on shorter cuts.
- Top beam returning back with gas cylinders.

## **STANDART EQUIPMENT**

- Shear blades made from tough and wear-resistant alloyed material
  - Top blade: Two cutting edges.
  - Bottom blade: Four cutting edges.
- 750 mm power backgauge with ballscrew spindles to 0.1 mm precision.
- Backgauge digital readout control.
- Digital stroke counter.
- Foot pedal control for single and repetitive cutting cycles.
- 1000 mm squaring arm with scale, T-slot and flip-stop.
- Front support arms in 1000 mm length.
- Work table with filler plates, ball transfers and hand slots.
- Emergency stop buttons.
- Shadow line facility with fluorescent lighting.
- See-through finger guard.



**PRECISION**

Hydraulic holddown system.



## HYDRAULIC SYSTEM

Compact, low-maintenance hydraulic unit



# Baykal

## CYBELEC CYBTOUCH

**Standard for  
MGH and HGL**

Cybelec CybTouch control unit is specifically designed for sheet-metal cutting, particularly for swing beam shears.

With its vivid color touch screen and a high integration of functions, it was designed so that anybody could start using it right away.



**CONTROL UNIT**

## CYBELEC CYBTOUCH

### Standard for HNC

Cybelec CybTouch control is a multi-axes control for high level automatic shears.

It manages up to 2 back gauges axes and 2 front gauges axes, as well as the angle and cutting length using potentiometers, linear encoders or a timer. Additionally the CybTouch handle full sheet supports, 2 or 3 positions cycles and many other shears features as Return to sender function.





# Baykal

## ESA 625

**Optional for MGH and HGL**

Compact design control unit with 7" touch screen, easy learning interface, and the possibility of storing thousands of part programs brings efficiency for your applications. It is now available for HGL and MGH as an option

## ESA 630

Optional for HNC

Performance level control unit with 10" touch screen and algorithms to make the most of the machines in all applications brings efficiency for your applications. It is now available for HNC as an option.



Type	
Model	
Working capacity	2000 mm
Cutting length	400
Block voltage	0.1 Hz / 100
Rated power	200
Rated pressure	100
Stroke per second	10000
Blade weight	20
Length	400
Width	400
Height	400



**MANUAL BLADE GAP ADJUSTMENT**

**Standard for MGH and HGL**



**BLADE GAP ADJUSTMENT**

Rapid blade gap adjustment mechanism





**MOTORIZED FRONT FEEDING SYSTEM (OPTIONAL)**



**SCRAP SEPARATOR AND CONVEYOR SYSTEM (OPTIONAL)**



### **SQUARING AND FRONT ARMS**

**1000mm Squaring arm with T-Slot, Scale and Flip Stop for HNC, MGH and HGL. Front support arm with T-Slot, Scale and Flip Stop is standard for HNC and optional for MGH and HGL.**



**THROAT GAP**

**350mm standard for HNC, 250mm standard for MGH,  
500mm optional for HNC and MGH**

## FRONT & REAR SAFETY



### FIXED FINGER GUARD

Standard for HNC, MGH and HGL



### FINGER GUARD WITH LIGHT BARRIER

Optional for HNC, MGH and HGL



### 1000MM LIFT-UP FRONT FINGER GUARD

with electrically interlocked safety switch

Optional for HNC, MGH and HGL

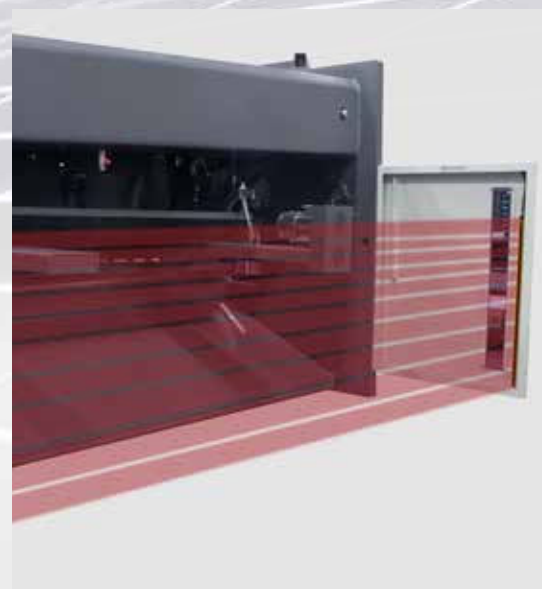

### REAR LIGHT BARRIER

## BACKGAUGE



### **MOTORIZED SWING-UP BACKGAUGE**

L=750mm  
(Standard for HGL)  
L=1000mm  
(Standard for MGH)  
(Optional for HGL)



### **MECHANICAL SWING-UP BACKGAUGE**

L=1000 mm  
(Standard for HNC)  
(Optional for HNC 3000mm and 4000mm)



### **HYDRAULIC SWING-UP BACKGAUGE**

L=1000mm  
(Optional for HNC)

## PNEUMATIC SHEET SUPPORT (OPTIONAL)

### D TYPE HEAVY DUTY PNEUMATIC SHEET SUPPORT SYSTEM



Option for Guillotine Shears (HNC,MGH)  
between 13mm to 20mm (MS)

Pneumatic sheet support consists of roller support arms mounted on a shaft. These support arms are 900 mm in length starting from the lower blade. The support arms, which are moved by the pneumatic cylinder, are in the upper position before cutting and they prevent the sheet to be cut from sagging. When the cutting is started, the support arms move downwards and since the support arms are jointly connected, they are constantly in contact with the cut sheet. At the end of the cut, the support arms, which become parallel with the ramp sheets, allow the cut sheet to slide more easily and fall behind the machine. Pneumatic sheet support system is completely controlled from the control panel. Pneumatic sheet support system is activated or deactivated with the On-Of control button.

## PNEUMATIC SHEET SUPPORT (OPTIONAL)

### A TYPE PNEUMATIC SHEET SUPPORT SYSTEM



Option for Guillotine Shears (HNC, MGH and HGL) until cutting capacity 13mm (MS)

Pneumatic sheet support consists of roller support arms mounted on a shaft. These support arms start 200mm from the lower blade and their length is 300 mm. The support arms, which are moved by the pneumatic cylinder, are in the upper position before cutting and they prevent the sheet to be cut from sagging. When cutting is started, the support arms move down. At the end of the cut, the support arms, which become parallel with the ramp sheets, allow the cut sheet to slide more easily and fall behind the machine. Pneumatic does not support parts smaller than 200mm. Pneumatic sheet support system is completely controlled from the control panel. Pneumatic sheet support system is activated or deactivated with the On-Of control button.

## PNEUMATIC SHEET SUPPORT (OPTIONAL)

### U TYPE UNIVERSAL PNEUMATIC SHEET SUPPORT SYSTEM



- With Transfer Balls
- With Brushes
- With Roller

Option for Guillotine Shears (HNC, MGH and HGL) until cutting capacity 13mm (MS)

**U type Pneumatic sheet support system has two operating modes:**

1st mode - It is used in thin sheet metal cutting to prevent sagging of the sheets and to be cut in precise dimensions. Pneumatic sheet support system works in 2 stages. In sheet metal cutting (while the upper jaw moves down) Pneumatic sheet support shifts from idle position to top position. After the cut is finished (while the upper jaw moves up), the pneumatic sheet support moves downward and allows the cut sheet to slide down. Cutting strip narrower than 35 mm is not recommended in this mode.

2. Mode - In this mode, the Pneumatic sheet support switches from idle position to top position, and after the cutting is finished, it switches back to first position. In this case, the cut sheet remains on the pneumatic support and by moving the back gauge forward, it is possible to take the cut sheet from the front. It is recommended that the cut length of the cut sheet should be up to 500 and the width should be min 50 mm. For longer lengths, when the cut sheet is on the pneumatic sheet support, the sheet cut at first position should not hang between the pneumatic support arms, otherwise it may rest on the lower blade while pushing it forward.

## OPTIONS



### **ANTI TWIST SYSTEM** OPTIONAL FOR HNC

Anti-Twist system prevents cutting sheet material from twisting in narrow and strip cuttings by holding straight during the cutting process against to blade movements.



### **DRAWER FOR SMALL PIECES**

Enable to take small cut parts from the front easily.

Optional for HNC, MGH, HGL



### **LASER CUTTING LINE**

Enable to see clearly the cutting point

Optional for HNC, MGH, HGL



### **SHADOW LINE**

Standard for MGH, HNC, HGL



### **ANGLE GAUGE**

Optional for HNC , MGH and HGL

This device provides accurate and easy material handling in the angled cuttings.



### **RTS FUNCTION**

Standard for U type pneumatic sheet support system

Precisely cut plate via the assistance of U type pneumatic sheet support system at the rear is being returned to the front of the machine by this system.

# HNC

## • HYDRAULIC VARIABLE-RAKE GUILLOTINES

# TECHNICAL DATA

TYPES	Capacity		Cutting Length	Rake Angle	Main Motor	Working Pressure	Number of Holddowns	Strokes Per Minute	Capacity of Oil Tank	Backgauge Range	Backgauge Motor	Approx. Weight	A	B	C	D	E	F	G	H
	≤450 N/mm <sup>2</sup>	≤700 N/mm <sup>2</sup>																		
	mm	mm	mm	degree	kW	kg/cm <sup>2</sup>	pcs.	cuts/min.	Lt	mm	kW	ton	mm	mm	mm	mm	mm	mm	mm	mm
HNC 3106	6	4	3070	0.5°-1.5°	11	260	16	20-32	240	1000	0.55	7.8	3450	430	1650	490	1000	350	800	2100
HNC 3110	10	6	3070	0.5°-2.0°	22	260	16	12-18	360	1000	0.55	11	3480	430	1800	450	1000	350	800	2200
HNC 3113	13	8	3070	0.5°-2.5°	30	260	16	9-14	360	1000	0.55	13	3520	430	1920	415	1000	350	800	2300
HNC 3116	16	10	3070	0.5°-3.0°	30	260	15	8-14	400	1000	0.55	16.5	3540	430	1965	365	1000	350	900	2480
HNC 3120	20	13	3070	0.5°-3.0°	37	260	16	6-10	400	1000	0.55	21	3580	430	2350	220	1000	350	1000	2700
HNC 3125	25	16	3070	0.5°-3.5°	45	260	15	4-6	600	1000	0.55	23	3560	430	2280	275	1000	350	1100	3220
HNC 4106	6	4	4070	0.5°-1.5°	11	260	21	16-25	360	1000	0.55	12	4460	430	2000	400	1000	350	900	2250
HNC 4110	10	6	4070	0.5°-2.0°	22	260	20	9-14	360	1000	0.55	15	4500	430	1920	410	1000	350	900	2360
HNC 4113	13	8	4070	0.5°-2.5°	30	260	20	7-14	400	1000	0.55	18	4520	430	2280	315	1000	350	1000	2630
HNC 4116	16	10	4070	0.5°-3.0°	30	260	21	7-12	400	1000	0.55	23.5	4540	430	2300	280	1000	350	1000	2800
HNC 4120	20	13	4070	0.5°-3.0°	37	260	21	6-9	400	1000	0.55	26	4570	430	2350	230	1000	350	1100	2900
HNC 6106	6	4	6070	0.5°-2.0°	18.5	260	30	12-18	360	1000	0.55	25	6460	430	2200	880	1000	350	1000	2690
HNC 6110	10	6	6070	0.5°-2.0°	22	260	30	6-10	400	1000	0.55	30	6480	430	2200	795	1000	350	1000	2750
HNC 6113	13	8	6070	0.5°-2.5°	30	260	30	6-10	400	1000	0.55	38	6520	430	2350	800	1000	350	1200	3090
HNC 6116	16	10	6070	0.5°-3.0°	30	260	30	5-9	400	1000	0.55	43	6540	430	2500	870	1000	350	1200	3250
HNC 6120	20	13	6070	1.0°-3.0°	37	260	30	5-9	600	1000	0.55	48	6560	430	2500	730	1000	350	1200	3330

Design and specifications are subject to change without notice

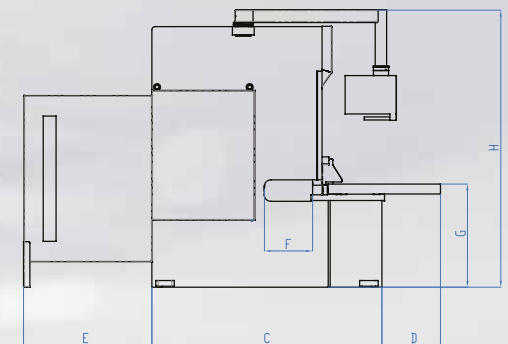
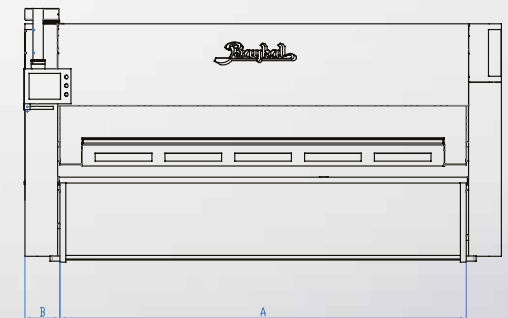

# MGH

## • HYDRAULIC SWING-BEAM SHEARS

# TECHNICAL DATA

TYPES	Capacity		Cutting Length	Rake Angle	Motor Power	Number of Holddowns	Strokes Per Minute	Capacity of Oil Tank	Backgauge Range	Backgauge Motor	Approx. Weight	A	B	C	D	E	F	G	H
	≤450 N/mm <sup>2</sup>	≤700 N/mm <sup>2</sup>																	
	mm	mm																	
MGH 3106	6	4	3060	1.5°	11	17	8	170	1000	0.37	7000	3340	430	1600	500	1000	250	800	1825
MGH 3110	10	6	3060	2.0°	22	17	12	170	1000	0.37	9200	3420	430	1775	500	1000	250	800	1850
MGH 3113	13	8	3060	2.4°	30	17	12	220	1000	0.37	11500	3450	430	1985	500	1000	250	900	2060
MGH 3116	16	10	3060	2.7°	30	17	7	220	1000	0.37	15500	3410	430	2150	400	1000	250	900	2230
MGH 3120	20	13	3060	3.0°	37	18	7	280	1000	0.37	19600	3470	430	2140	400	1000	250	900	2440
MGH 4110	10	6	4060	2.0°	22	23	10	170	1000	0.37	13000	4370	430	1975	400	1000	250	800	1910
MGH 4113	13	8	4060	2.2°	30	23	8	220	1000	0.37	16100	4400	430	1975	400	1000	250	900	2160

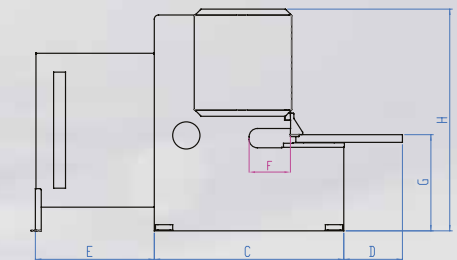
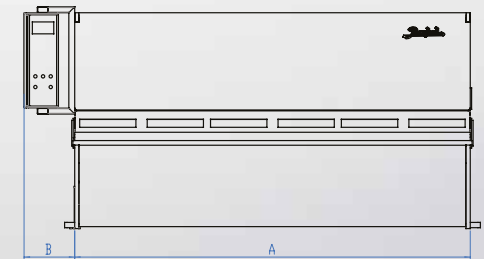

Design and specifications are subject to change without notice

# HGL

## • HYDRAULIC SWING-BEAM SHEARS

# TECHNICAL DATA

TYPES	Capacity		Cutting Length	Rake Angle	Motor Power	Number of Holddowns	Strokes Per Minute	Capacity of Oil Tank	Backgauge Range	Backgauge Motor	Approx. Weight	A	B	C	D	E	G	H
	≤450 N/mm <sup>2</sup>	≤700 N/mm <sup>2</sup>																
	mm	mm																
HGL 2106	6	4	2060	1.6°	11	13	26	160	750	0.55	4000	2260	430	1210	480	1000	800	1580
HGL 2606	6	4	2560	1.6°	11	15	24	160	750	0.55	4700	2760	430	1260	480	1000	800	1570
HGL 3106	6	4	3060	1.6°	11	17	20	160	750	0.55	5500	3260	430	1320	480	1000	800	1570
HGL 3108	8	5	3060	1.8°	15	17	13	160	750	0.55	6450	3305	430	1450	480	1000	800	1650
HGL 3706	6	4	3660	1.2°	11	20	18	160	750	0.55	7300	3965	430	1450	480	1000	800	1650
HGL 4106	6	4	4060	1.2°	11	23	12	160	750	0.55	9400	4305	430	1560	430	1000	900	1750

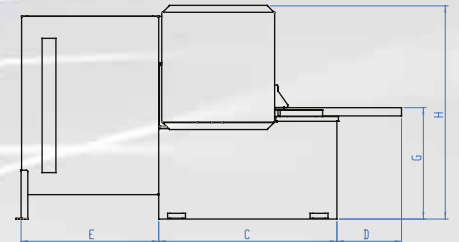
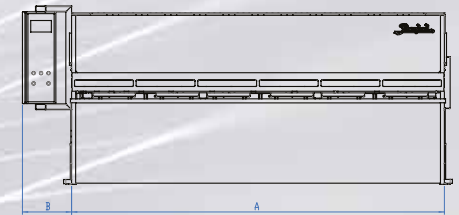

Design and specifications are subject to change without notice

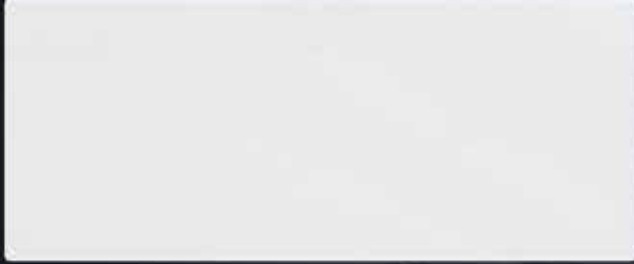

Ö.S.B. Lacivert Cd. 2.Sk. No.1/A 16140 Nilüfer BURSA/TURKEY  
T : +90 224 294 77 00 F : +90 224 243 12 86  
E-mail : baykal@baykal.com.tr

   / BaykalMachinery

05 / 2023 - REV / 01